

Wherever critical filtration is required ClaRite® belongs

The ClaRite filter is a vertical pressure vessel housing permanent tubular filtering elements which can be effectively precoated with a filter aid and backwash cleaned in place. It is designed to remove extremely fine suspended matter from liquids with retention down to 0.1 micrometer, and is most effectively applied with liquids having less than 1% (by weight) suspended solids. Croll-Reynolds Engineering has been producing custom and standard process industry equipment for more than half a century. Nowhere else will you find such depth of experience to help you meet exacting performance requirements.

Typical ClaRite Applications

- Adipic Acid, Hot Crude
- Ammonium Bisulphate
- Aqua Ammonia
- Boiler Feedwater (Fossil and Nuclear)
- City Water
- Cooling Water
- Crude Naphthalene
- Detergents
- Diazo Solutions
- Diethanolamine
- Elastomer Intermediates
- Ferric Chloride
- Metallic Electrolytes
- Molten Carbonates
- Monoethanolamine
- Nuclear Fuel Pool Water
- Offshore Water Flood
- Pharmaceutical Process Solutions
- Photographic Solutions
- Plating Solutions
- Potassium Chloride Brine
- Radioactive Waste Fluids
- Refinery Condensate
- Shampoo
- Sodium Molybdate
- Toxic and Non-Toxic Brines
- Urea
- Vinegar
- Water Containing Colloidal Silica

Catalog 71F gives complete details.

ClaRite®

CROLL-REYNOLDS ENGINEERING CO., INC.

1122 Main Street, Stamford, Connecticut 06902
203•324-7326 • N.Y. 212•267-5531

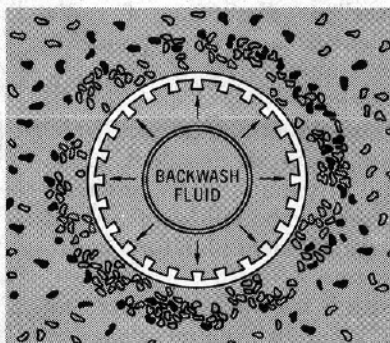
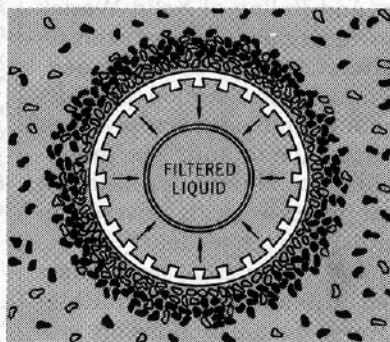
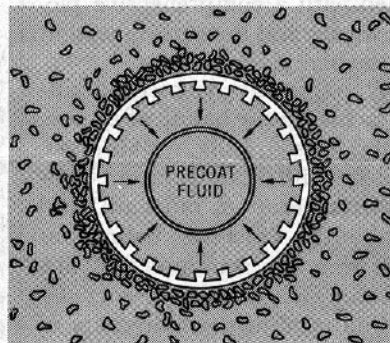

sive than disposal practices, this is an unfortunate omission.

Photographs illustrating the described processes, and showing details of some of the equipment discussed, would have been of value to the reader.

In conclusion, even though the book is 1,127 pages long, it cannot be categorized as a definitive work. The author has tried to cover too many subjects and, therefore, has left certain areas with little or no detailed material. Nevertheless, the work deserves a place in a reference library on solid waste management because of its scope of coverage.

The New Heat Transfer. Vol. II

By E. F. ADIUTORI

Ventuno Press, Box 40321, Cincinnati, OH 45240. 230 pages. \$19.95.

Reviewed by Otto Frank, Process Design Group Leader, Allied Chemical Corp.

The second volume of "The New Heat Transfer" continues Mr. Adiutori's running battle with the engineering establishment. It also carries over from the first volume [reviewed in *Chem. Eng.*, Feb. 3, 1975, p. 9] a rambling style, overindulgence in convoluted metaphors, and rhetoric overkill. We are again confronted mainly by the author's philosophical outlook and very little in the form of practical procedures for dealing with specific engineering problems.

This book, as was its predecessor, is a crusade against dimensional analysis, dimensionless groups, dependence on power functions, and the fragmentation of natural phenomena into small segments as a means of avoiding their nonlinear behavior. Although it is the author's stated objective to discuss here the research effort required to develop basic engineering data, the text is interspersed with so many digressions and such an obsessive defense of concepts that it is difficult to sustain one's interest in the technical aspects of the presentation.

It is Mr. Adiutori's practice to use one or two very selective examples to illustrate the overall validity of his theory. Thus he restricts himself to in-tube forced-convection heat transfer to expound on the development

In chemical services stay on stream with Dura Seal.[®]

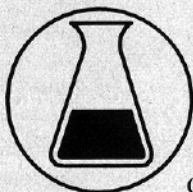

Productivity Insurance.

When facing severe sealing problems, maintain productivity with Dura Seals. Depend on them to meet adverse sealing conditions involving temperature extremes, high speeds and pressures, corrosion, abrasion, volatility, toxicity, and non-lubricating liquids encountered in the chemical processing industries.

You are invited to submit your sealing requirements and blueprints for complete analysis and recommendations, in full confidence and without obligation.

Ask today for Catalog 520 describing types and applications of Dura Seals.



Marketing Services
Durametallic Corporation
Kalamazoo, Michigan 49001, U.S.A.

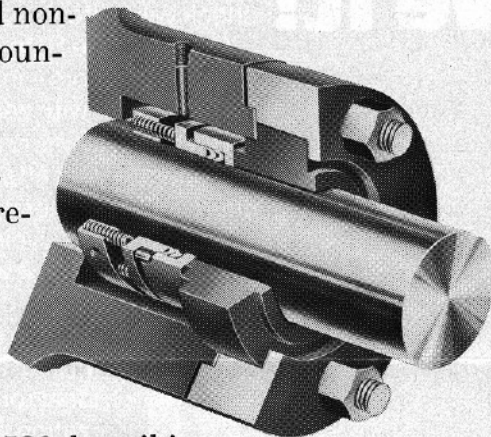

Type RO-TT



DURAMETALLIC

SEALING SYSTEMS WORLDWIDE

Be Sealing You—Booth 2211 N.Y. Chem Show

of a "new" correlation that he claims is superior to the classical relationships. He rejects specific heat, viscosity and thermal conductivity as correlating parameters, and wants them replaced solely by a temperature function. However, it may be difficult to convince the engineering fraternity that substituting three constants, empirically determined for each fluid, into the expression:

$$q \rightarrow G^{0.8} D^{-0.2} (a + bT + cT^2) T$$

is a more-rational approach than using the generalized equation

$$q = 0.023 \frac{\Delta T k}{D} \left(\frac{DG}{\mu} \right)^{0.8} \left(\frac{C\mu}{k} \right)^{0.4}$$

Just because dimensional analysis has been misused by some investigators is not sufficient justification to throw out the baby with the bathwater.

To prove that the old heat transfer cannot properly deal with highly nonlinear phenomena, Mr. Adiutori belabors at length a single correlation on surface film cooling presented in a 1961 article. He asserts that it was investigated over too small an operating range to make it applicable for the design of gas turbines and rocket nozzles. No indication is given that anything else has ever been published in this field by other investigators. (It should be noted, in passing, that there are only five reference notations in the entire Vol. II.)

The author proposes experimental techniques that, while having merit, are certainly not unique. Yes, it is a good idea to record many data points, over the greatest possible range, and plot them on linear graph paper. By all means try to correlate parameters that are normally measured experimentally, then establish their functionality, and finally determine variable interactions. No doubt about it, a large amount of data obtained by a careful experimenter during a well-planned test program will usually lead to good results. But in addition to accepting these truisms, Mr. Adiutori asks us to discard all existing correlating procedures that over the years have helped engineers generalize specific results.

The problem with both volumes (a third volume will complete the series) of "The New Heat Transfer"

Steam saving means energy conservation...and the

Nicholson Bellows Thermostatic Trap will not discharge live steam.

This is your energy conservation device!

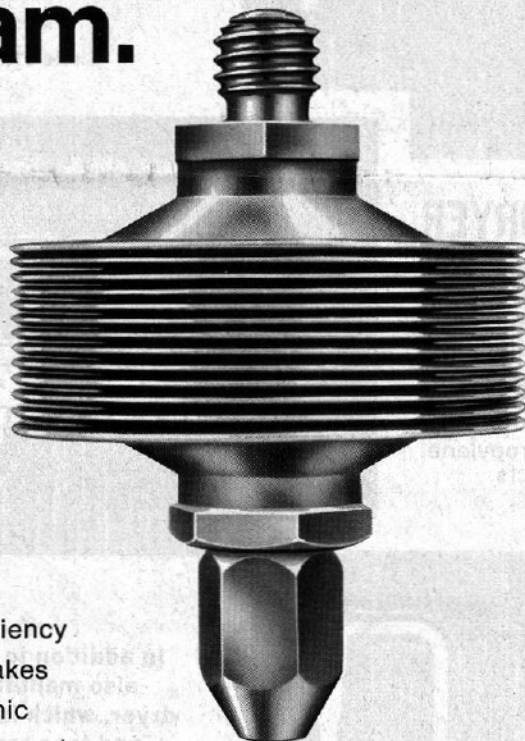

Test after test of thermal efficiency proves it. While Nicholson makes mechanical and thermodynamic traps to meet a variety of steam, air, gas and oil service conditions, the bellows trap, precision-built by Nicholson, combines the vital advantages of steam saving with efficient discharge of air and condensate, freedom from air binding, freeze-proof operation, and a remarkable miserly maintenance cost.

In today's critical situation, let Nicholson test its thermostatic trap in your plant. It's the headliner in our line, and can be on your steam lines. We will make a no-cost, no-obligation steam trapping survey for you. Call Nicholson Division of Datron Systems, Inc., 12 Oregon Street, Wilkes-Barre, Pa. 18702. (717) 824-8701.

STEAM TRAPS

• STRAINERS

• FLOATS

NICHOLSON



Circle 330 on Reader Service Card

14

CHEMICAL ENGINEERING NOVEMBER 10, 1975

is that Mr. Adiutori has written 460 pages when a few well-chosen paragraphs would have been sufficient. It is the constant repetition and labored defense of his subjective opinions that greatly dilute the impression he has set out to make.

Of course there is a point to be made when he states that in many cases "... today's engineering literature ... lacks an awareness of its real world purpose," and that we should guard against the repeated publication of essentially the same work "one data point per article." And further, some debate is justified regarding the procedures currently employed by scientific journals to evaluate and select their articles.

In summary, it must again be made clear that neither of Mr. Adiutori's books can by any measure be classified as a practical technical textbook. Primarily, they appear to be an expression of frustration coming from someone who feels that he has not been able to get his ideas accepted by his peers.

IN RAPID REVIEW

Human Engineering—The Body Re-examined. By John Lenihan. Pub. by and order directly from: George Braziller, Inc., One Park Ave., New York, NY 10016. 1974. 207 pages. \$7.95.

The Introduction of Group Technology. By John L. Burbidge. Halsted Press, div. of Wiley, New York. 1975. 267 pages. \$19.75.

Nanogen Index—A Dictionary of Pesticides. By Kingsley Packer. Pub. by and order directly from: Nanogens International, P.O. Box 487, Freedom, CA 95019. 1975. 256 pages. Hardcover \$32; Paperback \$24.50.

Process Quality Control. By Ellis R. Ott. McGraw-Hill, New York. 1975. 379 pages. \$14.95.

Detergency—Theory and Test Methods (Part II of three parts). Ed. by W. G. Cutler and R. C. Davis. Marcel Dekker, New York. 1975. 288 pages. \$21.75.

Metal-Slag-Gas Reactions and Processes. Ed. by Z. A. Foroulis and W. W. Smeltzer. Pub. by and order directly from: The Electrochemical Soc., Inc., P.O. Box 2071, Princeton, NJ 08540. 1975. 1,032 pages. \$20.

Statistical Models in Applied Science. By Karl V. Bury. Wiley, New York. 1975. 625 pages. \$24.95.